

Drive Systems for Electric Counterbalance Lift Trucks

Applications

- › 3/4 wheel Electric CB Lift Trucks
- › Ground Support Equipment
- › Airport Tractors

Standard features

- › Compact and modular design
- › Wet Disc Brakes
- › Easy to service
- › Optimized installation envelope
- › Maintenance free
- › Optimized gears profile for noise reduction
- › Integrated AC traction motors

Optional features

- › Integrated SAHR parking brake with low release pressure
- › External electromagnetic parking brake
- › Integrated must support

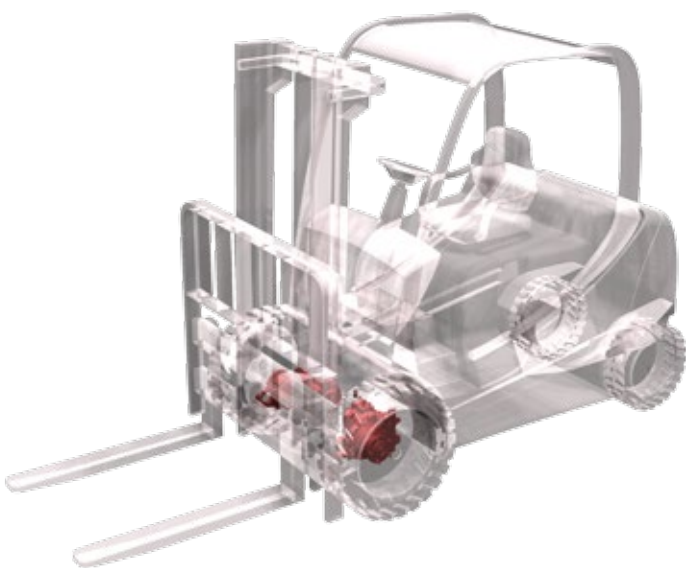

Class I

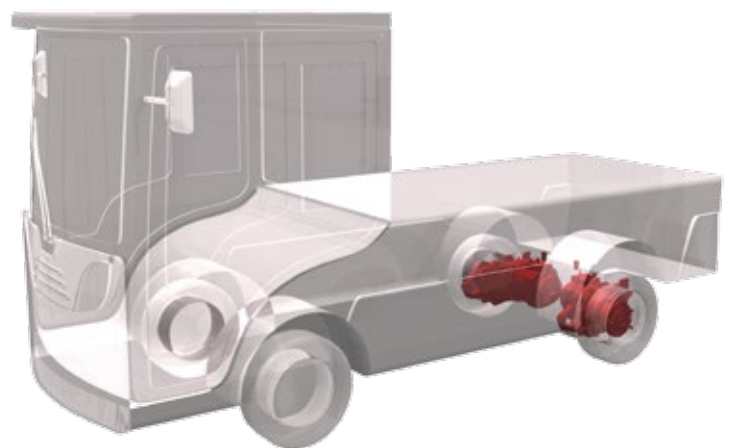

Class I / GSE

CLASS I – CLASS VI/E

		FDD 25	FDD 35
Lift capacity	Kg	2,500	3,500
Wheels load	Kg	6,400	8,800
Torque at wheels	Nm	3,000	8,200
Ratios		25.7	29.2
AC motor power		5 (X2)	7.5 (X2)
Service and Parking brakes		Wet Disc	Wet Disc
Flange to flange distance	mm	850	1,085
Frame mounting	mm	470	640
Mast mounting	mm	Customized	570
Wheel stud PDC	mm	145	160

